

PASS®

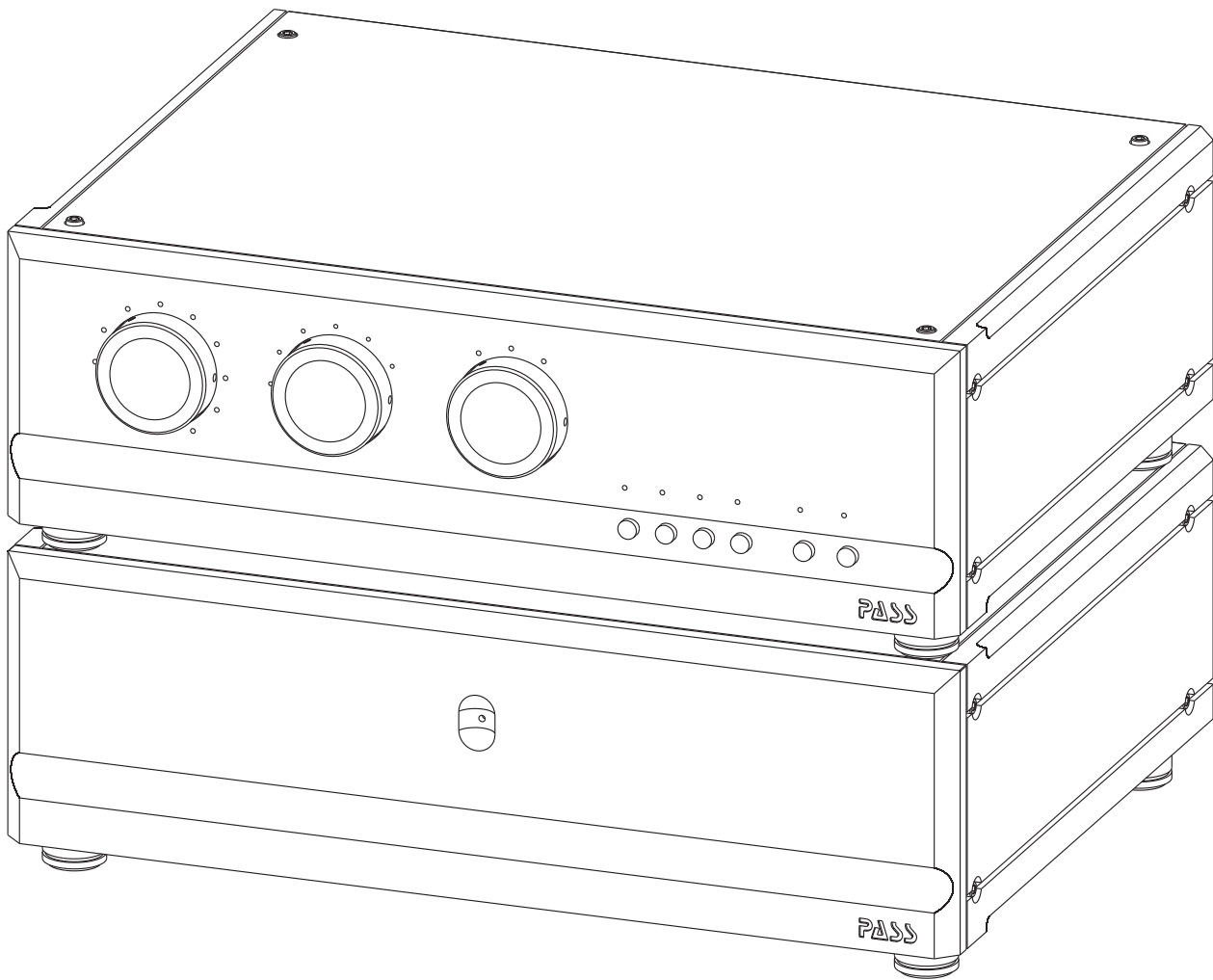

Xs Phono

Dual Chassis Phonostage

WARNING

For your protection please read the following:

Water and moisture: Electrical devices should not be used near water (as per example, near a bathtub, washbasin, kitchen sink, laundry tub, wet basement or swimming pool). Care should be taken such that objects do not have the opportunity to fall, and that liquid is never spilled onto or into the device enclosure through openings.

Power Sources: An electrical device must be connected to a mains power source in strict accordance with the supplied product owners manual. Please verify that the AC mains voltage specified in the product manual matches those requirements indicated on the unit and the AC voltage provided to your location by the power company.

Grounding: Adequate precautions should be taken so that the grounding provisions built into an electrical product are never defeated.

Power Cords: Pass Labs provides a power supply cord that meets all legislated requirements for the market in which the product was originally sold. If you choose to substitute an after-market product we urge you to choose one that is fully safety rated by the necessary local authority.

Power Cord Protection: Power supply cords should be routed so that they are not likely to be walked on, abraded, or pinched by items placed on or against them, paying particular attention to cords where they enter plugs or exit from a device. Never under any circumstance insert a cut or damaged power cord into a mains power socket.

Power and Signal: Cables should never be connected / disconnected with equipment powered up. Failure to heed this warning may damage or destroy equipment.

Ventilation: Power-amplifiers run hot, but you should be able to place your hands on them without discomfort. You must allow for this heat in installation, by providing for free air circulation around the product. Electronics should not be subjected to sources of excessive radiant heat. Excessive heat can shorten the life of the product and may cause the electronics to self protect and shut down.

Servicing: To reduce the risk of fire, electrical shock or other injuries, the user should not attempt to service the device beyond that which is described in the operating instructions. All other servicing must be referred to qualified service personnel.

For Units With Externally Accessible Fuse Receptacle: Unplug the device from all sources of power before changing or inspecting any fuse. Replace fuse with one of same physical size, type and rating as that specified by the manufacturer for that product.

Quick set-up

1) Place the Xs Phono control anywhere you wish, keeping in mind that you will want the wiring from the phono cartridge to the Xs Phono as short as possible.

2) Place the Xs power supply as distant from the control and any low level signal components as is practical. Most low level components and their interconnects benefit from electrically quiet environments.

3) If you're thinking of plugging the power supply into the wall, don't!

DO THIS FIRST:

a) Connect the two Powercon™ cables to the power supply chassis. (FIG 4, #1, #4)
Turn the connector clockwise till they click into place and lock (1/8 turn to the right)

b) Connect and the other ends of the cables to the gain chassis (FIG 2, #11, #13)
Turn the connector clockwise till they click into place and lock (1/8 turn to the right)

c) There is no particular preference for which power supply socket feeds either gain chassis socket, as long as both are connected.

4) Now you can plug the AC cord into the supply (Fig 4 #3) and the supply into the AC mains.

5) WAIT, it takes upwards of a minute for the system to come up and perform various housekeeping functions. When ready, the mute LED will go out. (FIG 1, #7)

6) Connect the Xs Phono to your preamp, and the turntable to your Xs Phono.

a) Select an input (FIG 1, #4)

b) Select Gain (FIG 1, #3)

c) Select Resistive Load (FIG 1, #1)

d) Select a Capacitive Load (FIG1, #2)

7) Now go listen

Now go about refining your cartridge loading options

When you're done, select "save" from the front panel (FIG 1, #5)

8) Sonically the Xs Phono will be good right out of the box but it will get better as it warms up. This can take a few days. Once it does, revisit your cartridge loading selection. If you need help, call us.

Introduction:

Wayne Colburn and the Pass Labs team were allowed to build the most advanced, best sounding phono-stage they could imagine; the phono-stage they all wished to have for their own homes. The Xs Phono is the result of this ambitious effort.

The Xs Phono is a true "dual-mono" design, the only component shared between channels other than casework, being the AC power connection to house power.

Once past the power cord the AC mains feed left and right channel power supplies, each totally independent from one another with their own dedicated transformer, filtering and regulation. The control section has its own regulated power supply as well.

Building upon the dual mono theme and topology each of the three inputs feature left and right gain channels, each on a separate, ceramic substrate circuit boards (6 circuit boards). This total independence starting at the power cord and continuing right through to the output connectors guarantees minimal noise and negligible channel to channel "cross-talk". The result is listening to music emerging from a quieter background and blooming into a richer, more precise soundstage.

Signal amplification from the phono cartridge inputs occurs prior to any input switching. This pre-amplification of the incoming signal prior to routing greatly reduces corruption of the low level analog information.

From the front panel of the Xs Phono you can select precise resistive loadings from 30 ohms through 47k-ohms, capacitive values from 100 pF through 750 pF in addition to gain of 56 dB, 66 dB or 76 dB. Blue LED's on the front panel indicate the loading values and gain settings.

For any input, choose the loading and gain settings best suited to that cartridge and push the "save" button on the front panel. Those values are now saved in memory and associated with that input. They will be recalled and applied to that input any time you select that input.

Frequently we come upon recordings which benefit from a slightly different cartridge loading, as for example slightly more capacitance. From the saved value it is quite trivial to change the capacitance (or resistance) loading for that one LP and then revert to the saved settings in memory by reselecting the same input, which restores the saved values.

While internally this makes for a very complex piece of hardware, it was of paramount concern was to make operation as intuitive and simple as possible. We believe that this goal has been achieved and the result is a piece which should not require much in the way of operational instructions.

Mute Function, the mute is applied automatically as inputs are selected and de-selected and during input or loading option changes. This allows for switching of the various functions with as few distractions as possible. The mute function may be applied manually, should

you need to pay attention to something else or simply want to queue a recording silently. Simply press the mute button. The blue LED above the button indicating it is active

The High Pass Filter can be left off for most recordings. When selected, the LED directly above the button will show blue, The High Pass Filter rolls off the low end response of the Xs Phono at 6dB per octave. The resulting 3dB roll-off at 20 Hz. maintains much of the bandwidth you desire, while minimizing various low frequency residual artifacts in less than perfect recordings. De-selecting the Hi-Pass function allows more of what is on the recording to come through.

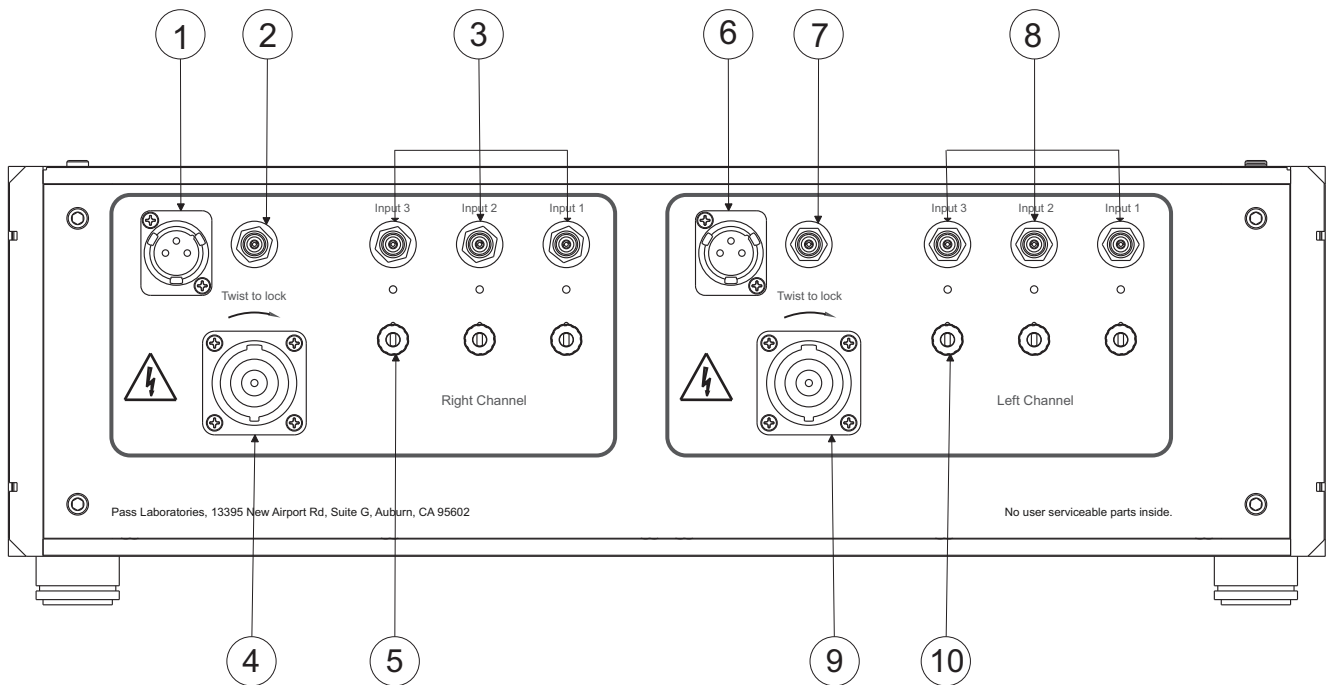

Figure 2.

1. Right XLR Output	6. Left XLR Output
2. Right RCA Output	7. Left RCA Output
3. Right Inputs	8. Left Inputs
4. powerCON	9. powerCON
5. Signal Ground Posts	10. Signal Ground Posts

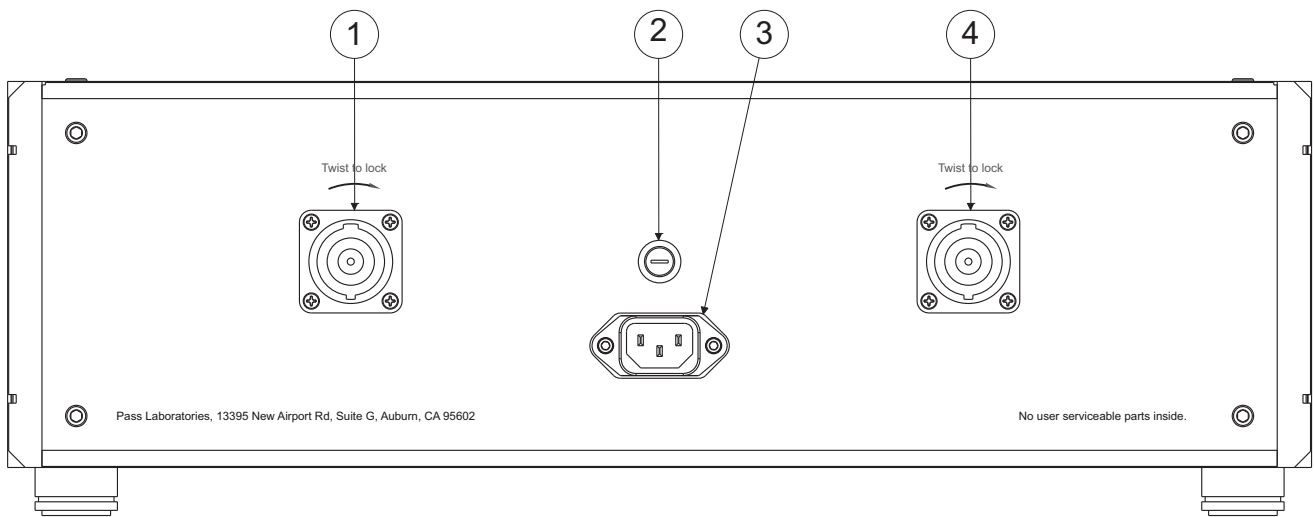

Figure 4.

1. powerCON	2. Fuse - see voltage label for size
3. AC Inlet	4. powerCON

Operation:

You can place the Xs Phono anywhere you wish. There are however practical considerations to placement that have the potential of enhancing performance.

Phono cartridges and associated wiring are by design very subject to ill effects from electromagnet pollution. The Xs Phono has the potential for very high gain and exceptional resolution, and it is not capable of discriminating between music and spurious noise as a result of location.

It is therefore advantageous to place your turntable in an area as free from electrical noise as possible. It is additionally advantageous to transfer the signal as cleanly and directly as possible from the phono-cartridge to Xs Phono by as short a path as possible. A path removed from the influence of AC power lines and large power supplies. Careful placement in this regard will pay sonic dividends.

When attaching cables to the Xs Phono or any audio device, the AC connection to house power should be the last connection made and the first removed.

Once you have the Xs Phono control chassis and power supply chassis in place you may connect them with the two supplied Powercon™ terminated umbilical cables. These cables are non directional. The powerCON receptacles on the chassis are identical, one for left and one for right, it doesn't matter which one is which.

Insert the powerCON terminated cable end into the matching chassis socket, rotate the cable end clockwise till the connector locks the cable into place. You should be able to hear and feel the connector lock, make sure it does. To remove a connector, pull back on the locking tab, rotate the cable end counter-clockwise 1/8 turn and remove.

The Xs Phono has 3 pairs of RCA inputs and will accept 1-3 tone-arms. The inputs area laid out on the back of the control chassis in blocks, Right Channel and Left channel. All inputs are identical. Each input has an auxiliary ground connection (white binding post). It is generally a good idea to connect this ground to your turntable. If you have multiple tone-arms on one table then some experimentation with grounds may be required for lowest noise.

The Xs Phono will output either a balanced or a single ended signal. Theoretically the balanced connection holds promise of transmitting signal from the Xs Phono to the line-stage with the lowest noise floors. Depending upon your line stage you may wish to try both. There is no reason that the Xs-phono could not drive two devices simultaneously as for example a line-stage and an A/D converter.

Presuming the umbilical power cables, analog input and output are all connected, go ahead and connect to the AC mains at this time. Please verify the line voltage at your location with the label on the back of the Xs Phono stage.

The Xs Phono has no power switch, it's designed to be always be powered up. You should

see a power LED On the supply and lamps around the loading switches on the control chassis. If you do not then check the fuse on the power supply rear panel. The value of the required fuse is printed on the rear of the power supply. In all instances the fuse will be a type 3AG / Littlefuse series 313 (1/4" x 1-1/4") (6.3mm x 31.8mm) glass fuse.

When you plug the Xs Phono into house power it takes upwards of 60 seconds for the unit to reach operational status. When the mute LED goes dark, the Xs Phono is fully operational.

Adjustment and Loading:

The Xs Phono allows: Resistive loading between 30 ohms and 47k-ohms, capacitive loading between 100pF and 750pF, Gain between 56dB and 76dB, and high pass function from the front panel of the control unit. The active value will always be indicated by a lit LED.

Cartridge loading and gain is a compromise between what works best for the cartridge and what sounds best in your system.

Start with a dynamic recording, the manufacturers suggested resistive loading, 100pf and 56 dB gain. If the gain seems low, increase it to 66 dB, if you start hearing distortion of the loudest notes, reduce the gain. Listening to a wide variety of music try increasing or decreasing the resistive loading. As you change the settings it will either sound better or worse. Do not decide on a setting based upon only one recording.

When you decide upon a setting press the "save" button. This will allow you to return to a favorite suite of settings. You may save settings for inputs 1, 2 and 3.

Use of the high pass filter is optional, it adds a 3dB roll off at 20 Hz to minimize low frequencies, otherwise low frequency extension is to below 5 Hz.

Once a setting is saved you may return to it by pressing the input selection button; however the front panel controls are always active and may be used to slightly compensate for less than ideal recordings without losing the saved settings.

Warranty:

Please check with the factory authorized distributor in the country where you are purchasing this product for specific warranty information.

All Pass Laboratories products purchased new from an authorized Pass Laboratories dealer in North America are covered by a transferable, limited 3-year warranty. This warranty includes all parts and labor charges incurred at the factory or factory specified repair facility, exclusive of any subsequent or consequential damages. Damage due to physical abuse is specifically excluded under this warranty.

For this warranty to apply the customer is responsible for returning the product unmodified to the factory within the specified warranty period. The customer assumes all responsibility for shipping and insurance to and from the factory or a factory specified repair facility. The conditions and stipulations of this Pass Laboratories warranty only applies to units originally sold new through an authorized dealer. Warranty on factory repair is 60 days and covers only the scope of the original repair.

Non-North America customers should consult with their original Pass Labs dealer or distributor for warranty repair instruction prior to contacting the factory or shipping product to the factory for repair.

Non-North American product must be returned to the country of origin for warranty service. Foreign distributors are only required to offer warranty service on Pass Laboratories product that they have imported, verifiable by serial number.

Please note: Conditions of warranty service and customer rights for product purchased outside the United States may vary depending upon the distributor and local laws. Please check with your local distributor for specific rights and details.

Any modifications to Pass Laboratories products that have not received written factory approval nullify all claims and void all provisions of the warranty and liability by the maker or authorized distributor. Should a modified product be returned to the factory for repair the owner will be required to pay all necessary charges for the repair in addition to those charges required to return the product to it's original configuration.

In the case of safety issues, no product shall be returned to the customer without those safety issues being corrected to the most recent accepted standards.

Removal or alteration of original Pass Labs serial numbers voids the factory warranty. Product with altered or missing serial numbers will be suspect as counterfeit or stolen product.

Pass Laboratories will not repair or in any way indemnify any counterfeit or cloned product.

Pass Laboratories does not offer products in voltages intended for international markets either to authorized Pass Labs dealers or to third parties located in the United States or Canada.

Pass Laboratories, 13395 New Airport Rd., Suite G, Auburn, CA 95602

Phone: 530.878.5350, Fax: 530.878.5358, Web: www.passlabs.com